

SX40i
SX50i

- SEMI VANDAL RESISTANT
- DAY & NIGHT FUNCTION
- HIGH DEFINITION CAMERA LENS
- A.C.E TECHNOLOGY
- FUTURISTIC COLOR DESIGN
- LOW CURRENT HEAT-LESS CIRCUIT
- MADE FOR LOW-LIGHT SURVEILLANCE

DAY / NIGHT
ENHANCED HIGH-RESOLUTION DOME CAMERA

Better colour accuracy **A.C.E**
Artificial.Color.Enhanced



Video with A.C.E Technology



Conventional camera without A.C.E

IT'S SEMI-VANDAL RESISTANT

The SX40i & SX50i is specially design to withstands against minor vandalism. The lower dome cup of the camera housing is made from ultra hard and clear polycarbonate material. It is design and manufactured to withstands against direct impacts up to 40 kgs. This feature is to prevent against minor vandalism cases such as stones throwing, accidental camera dropping while installing & etc...



Clearer & sharper video quality with WIDE-ANGLE-HIGH-RESOLUTION lens

No matter how good the camera specification is, the most important part of the camera are the camera lens. If the camera specification indicates that the camera are able to produce a 520 TV lines of horizontal resolution video quality, the camera will still not achieve the stated 520 TV lines specification if it uses a low resolution lens.

INOX - SX40i & SX50i dome cameras are in-built with a high resolution lens inside to produce a clearer & shaper video images. Users are guaranteed to satisfaction for the video quality produced.



DAY & NIGHT AUTOMATIC CHANGEOVER FUNCTION FOR 24/7 SURVEILLANCE

Whether it is during day or night, the camera still continues to produce an excellent surveillance video quality. It runs on color mode during daylight surveillance (above 1 LUX of lighting level) and automatically changes to black & white (night) when the surveillance area lighting level drops below 1 LUX. During this night function (B/W) mode, video images produce at this mode will be clearer & brighter compare to other conventional cameras that is in color mode during night surveillance.

<p>DAY</p> <p>COLOR</p>	<p>NIGHT</p> <p>B / W</p>	<table border="1"> <tr> <td data-bbox="948 1096 1119 1133">COLOR VIDEO</td> <td data-bbox="1148 1096 1319 1133">B/W VIDEO</td> </tr> <tr> <td colspan="2" data-bbox="948 1148 1319 1319"> </td> </tr> <tr> <td data-bbox="948 1319 1119 1348">> ABOVE 1 LUX</td> <td data-bbox="1148 1319 1319 1348">< BELOW 1 LUX</td> </tr> </table>	COLOR VIDEO	B/W VIDEO			> ABOVE 1 LUX	< BELOW 1 LUX
COLOR VIDEO	B/W VIDEO							
> ABOVE 1 LUX	< BELOW 1 LUX							

INOX®

DAY / NIGHT ENHANCED HIGH-RESOLUTION DOME CAMERA WITH SEMI-VANDAL RESISTANT HOUSING



470 TVL (Model: SX40i)
520 TVL (Model: SX50i)

Specifications:

MODEL	SX40i	SX50i
IMAGE PICK UP SENSOR	1/3" SONY Super HAD CCD	
SIGNAL PROCESSOR	SONY / JAPAN	
CCD TOTAL PIXELS	PAL: 537 (H) x 597 (V) NTSC: 537 (H) x 505 (V)	PAL: 795 (H) x 596 (V) NTSC: 811 (H) x 508 (V)
MIN. ILLUMINATION	0.3 LUX F1.2 @ 5600 K (AGC OFF)	0.5 LUX F1.2 @ 5600 K (AGC OFF)
VIDEO RESOLUTION	ENHANCED 470 TV LINES	ENHANCED 520 TV LINES
AUTO GAIN CONTROL	YES, ON	
WHITE BALANCE	AUTO TRACKING WHITE (ATW)	
ELECTRONIC SHUTTER SYNC SYSTEM	PAL: 1/50 ~ 1/100,000 SEC. / NTSC: 1/60 ~ 1/100,000 SEC. INTERNAL	
S/N RATIO	MORE THAN 48DB	
EXTRA ADVANTAGE	SEMI VANDAL RESISTANT (DOME CUP ONLY)	
LENS	3.6 MM (BOARD M12 Ø)	
DAY & NIGHT TECHNOLOGY IRIS	DAY (COLOR) / NIGHT (B/W) EE	
POWER INPUT	12 VDC	
OPERATING CURRENT	70 mA + - 10%	110 mA + - 10%
OPERATION TEMPERATURE	5 ~ 60 DEGREES CENTRIGRADE	
DIMENSION	105.5 MM (D) x 85 MM (H)	
CAMERA WEIGHT	APPROX. 300 GRAMS	

Dimension:

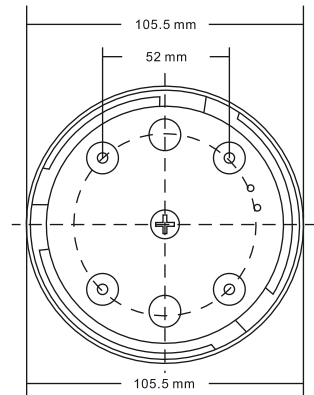
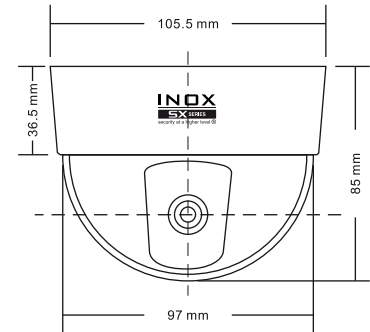

SX40i
ENHANCED 470 TV LINES

SX50i
ENHANCED 520 TV LINES

INOX SECURITY PTY. LTD.

- Canada (Incorporation No. BC 0722077)

AFRICA DISTRIBUTOR :
JETMAN INOX SECURITY EQUIPMENT AFRICA
www.jetman.co.za